



File Name: Cwst Army Manual.pdf

Size: 3567 KB

Type: PDF, ePub, eBook

Category: Book

Uploaded: 4 May 2019, 13:29 PM

Rating: 4.6/5 from 686 votes.

Status: AVAILABLE

Last checked: 17 Minutes ago!

In order to read or download Cwst Army Manual ebook, you need to create a FREE account.

[**Download Now!**](#)

eBook includes PDF, ePub and Kindle version

[**Register a free 1 month Trial Account.**](#)

[**Download as many books as you like \(Personal use\)**](#)

[**Cancel the membership at any time if not satisfied.**](#)

[**Join Over 80000 Happy Readers**](#)

Book Descriptions:

We have made it easy for you to find a PDF Ebooks without any digging. And by having access to our ebooks online or by storing it on your computer, you have convenient answers with Cwst Army Manual . To get started finding Cwst Army Manual , you are right to find our website which has a comprehensive collection of manuals listed.

Our library is the biggest of these that have literally hundreds of thousands of different products represented.



Book Descriptions:

Cwst Army Manual



These two events are done with swimming trunks or a swim suit on. After these two events are completed cadets put on ACUs and tennis shoes. The cadet must stand on the side of the pool. The site may not work properly if you dont update your browser. If you do not update your browser, we suggest you visit old reddit. Press J to jump to the feed. Press question mark to learn the rest of the keyboard shortcuts Log in sign up User account menu 1 CWST Manual I cant seem to find it anywhere. Its the 10 minute swim, 5 minute tread, equipment drop, rifle swim, and blindfolded drop. All rights reserved Back to top. Cadets must first swim laps for ten minutes without touching the sides or bottom of the pool. Cadets receive a five minute break, and then must tread water for another five minutes without touching the bottom or sides of the pool. These two swim events are done with PT uniforms shorts and tshirt on. Cadets then put on ACUs and tennis shoes to complete the following three events for the CWST. From the side of the pool, the Cadet must step backwards into the water. They must hold on to the M16 at all times, remove the blindfold, and then swim to the side of the pool. You may have accidentally mistype the page address, or followed an expired link. Anyway, we will help you get back on track. Why don't you try one of these pages for starters. For more information see our. Privacy Policy Accept and Close X. Uncontrolled high blood pressure in U.S. gets worse A striking reversal Trumps attacks on the military More trending news. Need help locating information about the CWST in the Army field manual. Thanks, Joe. Answer Save 3 Answers Relevance Anonymous 1 decade ago Favorite Answer Training Circular TC 2121 If thats what you were asking about 0 0 Anonymous 6 years ago With every day pass, our country is getting into more and more trouble. <http://tripura-infoway.com/tempimg/briggs-and-stratton-vanguard-repair-manual.xml>

- **army cwst manual, cwst army manual, cwst army manual pdf, cwst army manual download, cwst army manuals, cwst army manual 2017, army cwst manual.**

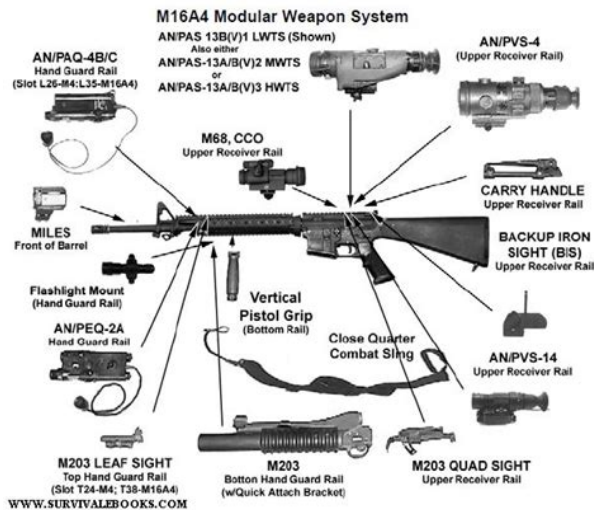

The inflation, unemployment and falling value of dollar are the main concern for our Government but authorities are just sleeping, they don't want to face the fact. Media is also involve in it, they are force to stop showing the real economic situation to the people. I start getting more concern about my future as well as my family after watching the response of our Government for the people that affected by hurricane Katrina. According to recent studies made by World Bank, the coming crisis will be far worse than initially predicted. Get your answers by asking now. How to know if I would be a good candidate for Army EOD. Does Biden have any idea about the words coming out of his mouth.If Biden wins will the secret service change the name of Air Force One to Nursing Home One. Terms Privacy AdChoices RSS Help About Answers. Community Guidelines. Leaderboard Knowledge Partners. International Sites. COREQUISITE Adaptive Tactical Leadership Lab MSC1 3101 L. COURSE DESCRIPTION MSC1 3101 is an academically challenging course were you will study, practice, and apply the fundamentals of Army leadership, Officership, Army values and ethics, personal development, and small unit tactics at the team and squad level. At the conclusion of this course, you will be capable of planning, coordinating, navigating, motivating and leading a team or squad in the execution of a tactical mission during a classroom PE, a Leadership Lab, or during a Situational Training Exercise STX in a field environment. Successful completion of this course will help prepare you for success at the ROTC Leader Development and Assessment Course LDAC which you will attend next summer at Fort Lewis, WA. This course includes reading assignments, homework assignments, small group assignments, briefings, case studies, and practical exercises, a midterm exam, and a final exam.<http://bhyper.com/allfiles/briggs-and-stratton-vanguard-service-manual-pdf.xml>

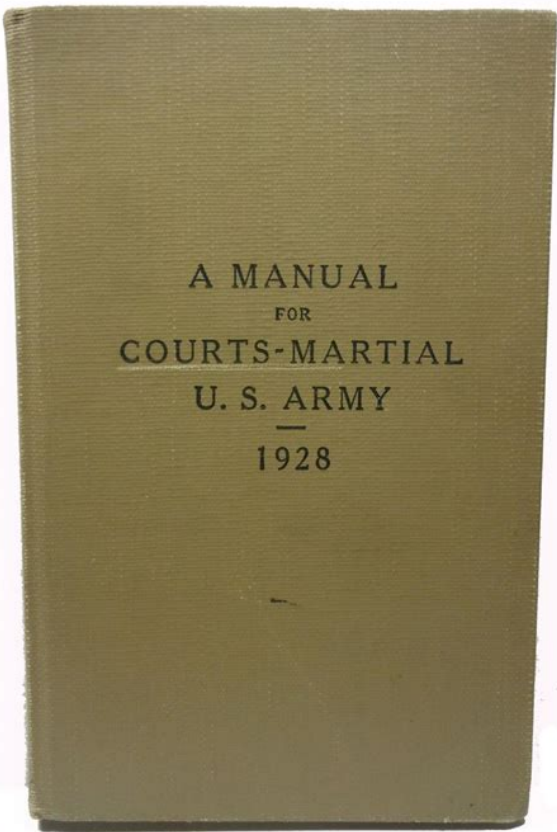
The image shows the front cover of a book. The cover is a plain, olive-green color with a slightly textured surface. The title is printed in a simple, black, sans-serif font, centered on the cover. The text reads: "A MANUAL" on the first line, "FOR" on the second line, "COURTS-MARTIAL" on the third line, "U. S. ARMY" on the fourth line, and "1928" on the fifth line. There is a small horizontal line between "U. S. ARMY" and "1928".

A MANUAL
FOR
COURTS-MARTIAL
U. S. ARMY
—
1928

You will receive systematic and specific feedback on your leader attributes values and core leader competencies from your instructor and other ROTC cadre and MSL IV Cadets who will evaluate you using the ROTC Leader Development Program LDP model. CREDIT HOURS This 3 credit hour MSCI 3101 course and 1 credit hour MSCI 3101 L lab requires 3 hours of classroom or direct faculty instruction and one 8hour Saturday leadership lab a month. It also includes up to 6 hours of out of class student work each week for approximately 15 weeks. Out of class work may include, but is not limited to required reading, library research, studio work, practical exercises, internships, written assignments, and study time for quizzes and exams. There will be various events that require attendance, to include Field Training Exercises FTXs, Physical Training PT, Army Physical Fitness Tests APFTs, Fund Raisers, Color Guards, Red Cross Blood Drives, the Military Ball, Raider Challenge meets, High School Drill Meets, Commissioning Ceremonies, and Guest Speaker Events. Contracted Cadets will be required to attend many, if not all, of these events. COURSE DESIGN This course was designed to be studentcentric with the onus of learning on the student, but facilitated by the instructor. Army Officers are expected to be lifelong learners who take responsibility and personal initiative for their learning. You must properly conduct your preclass assignments in order to come to class with a foundation of knowledge on the subject to be taught by your instructor. Doing so will allow your instructor to spend the majority of the class time on specific areas that are least understood from the preclass assignment rather than your instructor reteaching the subject from scratch. Your instructor has a wealth of experience and knowledge to share in the classroom—do your homework so your instructor can spend more time sharing his personal knowledge and experiences with your class.

Class will be conducted in an interactive manner with ample opportunities for small group discussions and practical exercises. Everyone will be responsible for contributing to the success of the learning experience. Thank you, for helping us keep this platform clean. The editors will have a look at it as soon as possible. We further strive to enhance learning and development by serving as the hub for studentcentered collaboration, programs, and services. Each student was provided a place to work during the summer, and was provided the book *How to Win Friends and Influence*

People, that was read and discussed as a group with DSC professional staff. This continues a grant funded for University District residents to promote a healthier lifestyle through discounted rates in the Donaghey Student Center Fitness Center. This was an excellent partnership we hope to continue in the future. This resulted in streamlining of services and communication, increased employee morale, and higher attention to detail and ownership of the building. The building is cleaner and more presentable as management and employees share the same vision for the facilities. This has allowed for increased collaboration as well as better accessibility for outside visitors who are utilizing the space. Specific elements that were examined include facility design standards, ADA standards, risk management recommendations, and operational recommendations. Findings were presented as an executive report to the Director of Recreational Facilities. These areas include facility design standards, Americans with Disabilities ADA requirements, state and local standards related to healthy and safe operation of sport facilities, risk management, and overall management and operations.

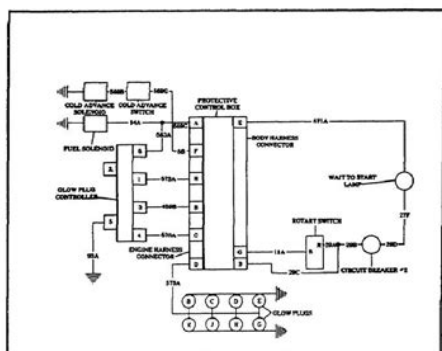

<https://www.thebiketube.com/acros-bosch-sds-jigsaw-1587avs-manual>

Through the evaluation of a comprehensive list of requirements, guidelines, and standards, specific recommendations for improvement were made as a way to ensure that the campus recreation facilities at the University of Arkansas at Little Rock serve the student population appropriately. There are two ways through the locker room which include from the basketball courts and from the Aquatics center. The DSC hosted 1207 events compared to 59 for the SSC and 16 for Coleman Recreational Facility. That way, every time you open a new tab you review 235 cards before doing something else, mixing these tiny chunks of flashcards reviewing through the day, which should also improve memory retention as interleaving comes into play. Or do you know how to improve StudyLib UI. Feel free to send suggestions. Its very important for us. Download EDU 604. Cadets learn to safely conduct training by understanding and employing the Composite Risk Management Process. Cadets learn how to use the Comprehensive Soldier Fitness CSF program to reduce and manage stress. PlatoonLeader Forum The PlatoonLeader forum is an interactive social networking site for the professional development of junior officers. This site provides Cadets the opportunity to engage

one's peers, learn from the experiences of others, and develop relationships in a virtual environment. MSLIV Cadets are strongly encouraged to register and participate on this forum. The link to PlatoonLeader is located on the ROTC Blackboard website under the Interesting Links block or at Learning Objectives The overall objective of this course is to prepare the student for success at the Basic Officer Leader Course BOLC B, which the student will attend upon graduation and commissioning and to develop the student into a leader imbued with the Warrior Ethos, who can think critically and will be capable of leading Soldiers in the Full Spectrum Operating Environment OE at their first unit of assignment.

<http://atmos-service.com/images/Davis-Manual.pdf>

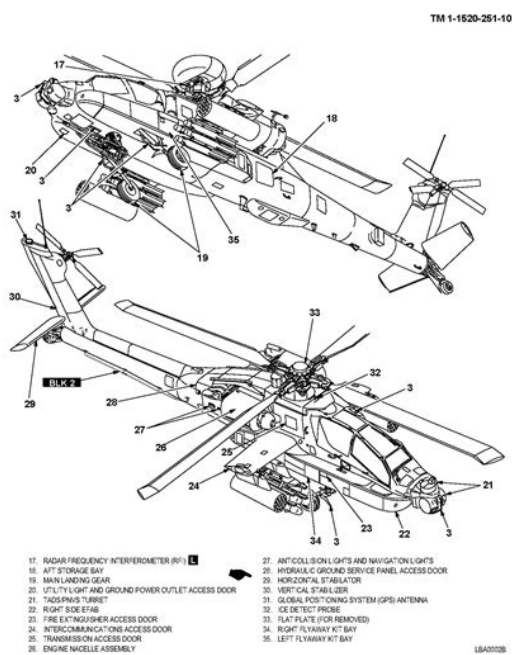

Figure 2-1. General Arrangement (Sheet 2 of 2)

Use or disclosure of this information is subject to the restriction(s) on the title page of this document.

Change 4 2-3

This course has specific learning objectives for the five tracks listed below. Leadership Apply Army leadership dimensions as Cadet battalion leaders. Evaluate fellow cadets using the Leadership Development Program LDP Values and Ethics. Apply Army leader ethics in decision making. Relate the law of war and rules of engagement to Army operations. Explain obligations as a US service member under the code of conduct Page 1 of 9 MSL 401, Adaptive Leadership Fall 2011/2012 Course Syllabus Revision Date 31 July 2011. Understand your role in the UCMJ process and explain the types of administrative discipline and separations Personal Development. Identify Resiliency Training skills in the Comprehensive Soldier Fitness CSF Program. Identify methods to reduce and manage stress as a leader. Evaluate subordinate Cadets using LDP cards and Army Writing Standards Officership. Explain the profession of arms and officership as it relates to civilian professions. Perform the duties of a Cadet battalion staff position. Understand the duties of staff organization roles and responsibilities. Counsel underclass Cadets to improve performance. Write an officer evaluation report support form. Explain the importance of actively managing your career as an Army officer. Conduct training meetings to plan, execute, and assess training Tactics and Techniques. Mentor and evaluate underclass Cadets during tactical operations. Apply the training management process through OPORDs, rehearsals and rock drills. Class participation You are expected to participate actively in learning through critical reflection, inquiry, dialogue, and group interactions. This includes participating in class discussion, sharing personal perspectives and

experiences related to principles discussed in class or reading, working with fellow students to engage in class exercises, and leading lab exercises.

<http://moj-svet.com/images/Davis-Loader-Manual.pdf>

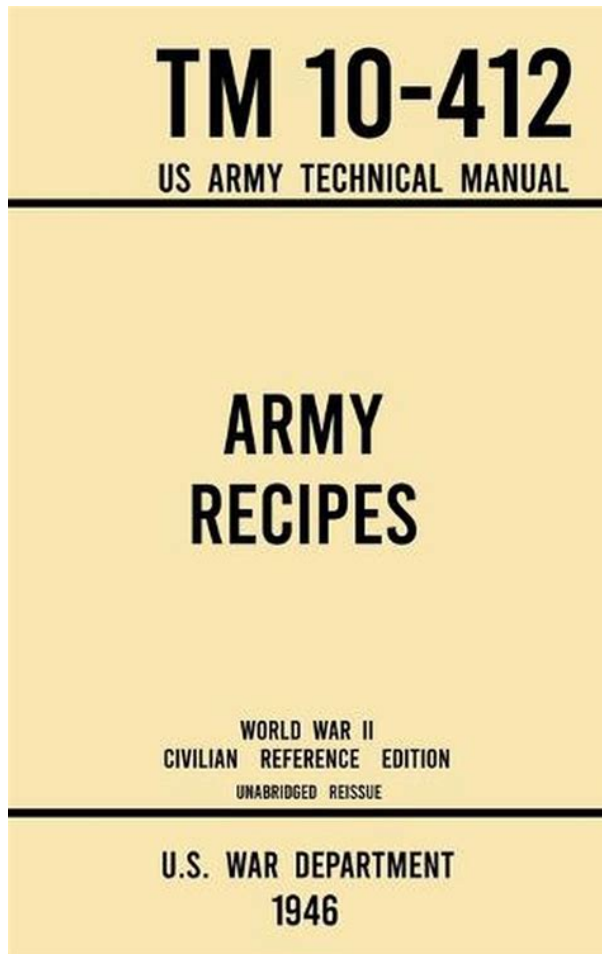

Page 2 of 9 MSL 401, Adaptive Leadership Fall 2011/2012 Course Syllabus Revision Date 31 July 2011 Quizzes Quizzes will be given throughout the semester to assess your progress in learning the principles and practices related to the course material. MidTerm Exam A midterm exam will be given to assess your knowledge achieved during the first half of the semester. Final Exam A cumulative final exam will be given to assess your knowledge achieved throughout the course of the semester. APFT As a future officer, you are expected to set the example for physical fitness according to Army regulations. You will be required to take a diagnostic APFT at the beginning of the fall semester and a forrecord APFT at the end of the semester. Ten percent of your final grade will be from your score on the record APFT. Contracted Cadets are required to participate in all ROTC activities as stated in their contract. Students auditing this class are encouraged but not required to participate in ROTC activities outside of the classroom. Combat Water Survival Test This is a requirement to commission. Failure to pass will result in you being enrolled in an ROTCfunded swimming improvement class until you can successfully complete the CWST. Homework There will be various homework assignments throughout the semester to include writing Army Memorandums, After Action Reviews, and other writing assignments. The following grading scale will be used based on 100 points possible. 90100 A 8089 B 7079 C Every attempt will be made to offer adequate written assessments in explaining evaluations. All late papers and assignments will receive a 10% reduction in grade. Course Design This course was designed to be studentcentric with the onus of learning on the student, but facilitated by the instructor. You must properly conduct your preclass assignments

in order to come to class with a foundation of knowledge on the subject to be taught.

As a minimum, read the student text assignment and scan the class slides before each class. Doing so will allow your instructor to spend the majority of the class time on specific areas that are least understood from the preclass assignment rather than your instructor reteaching the subject from scratch. Everyone will be responsible for contributing to the success of the learning experience.

Page 4 of 9 MSL 401, Adaptive Leadership Fall 2011/2012 Course Syllabus Revision Date 31 July 2011

Uniforms and Appearance Dress appropriately for class. No tank tops, short shorts, revealing clothing, flip flops or miniskirts will be allowed. You are expected to wear ACUs Army Combat Uniform to all labs and adhere to Army Regulation 6701 with regard to uniforms and appearance.

Collaboration You are encouraged to work together with your fellow MSL IV Cadets and seek guidance and help from your instructor and other ROTC cadre.

Special Needs The American with Disabilities Act of 1990 requires universities to provide a reasonable accommodation to any individual who advises us of a disability. If you have a limitation that requires an accommodation or an academic adjustment, please arrange a meeting with me at your earliest convenience.

Office Hours and Appointments I am available any time you have a question and have an open door policy if you need to meet to discuss assignments, issues, or concerns.

Student Text MSL 401, Adaptive Leadership, Pearson Custom Publishing, 2008. September 1997. AR 6233, Evaluation Reporting System. 10 August 2007. AR 635200, Active Duty Enlisted Administrative Separations. 8 February 2005. Department of the Army Training Circulars TC o TC 322.20, Army Physical Readiness Training. August 2010. o TC 2520, A Leader's Guide to After Action Reviews. 30 September 1993. o TC 2530, A Leader's Guide to Company Training Meetings. 27 April 1994. Other Resources o Manual for CourtsMartial United States, 2008 Edition.

<https://www.fotografoeventimilano.com/wp-content/plugins/formcraft/file-upload/server/content/files/16289808ef1949---canon-digital-ixus-75-manual-download.pdf>

Page 8 of 9 MSL 401, Adaptive Leadership Fall 2011/2012 Course Syllabus Revision Date 31 July 2011

Bennis, W. G. 2003. On becoming a leader. Headquarters, Department of the Army, Field Manual 1 2005. The Army. Washington, D.C. U.S. Government Printing Office. Headquarters, Department of the Army, Field Manual 622 2006. Army leadership. Washington, D.C. U.S. Government Printing Office.

Kotter, J. P. 1996. Leading change. Boston Harvard Business School Press.

Wong, L. 2004. Developing adaptive leaders The crucible experience of Operation Iraqi Freedom. Carlisle Barracks, PA Strategic Studies Institute.

Wong, L. 2002. Stifling innovation Developing tomorrow's leaders today. Carlisle Barracks, PA Strategic Studies Institute.

This is a very general list. For a more complete listing of leadership references see Human Dimensions of Strategic Leadership, published by the U.S. Army War College Library December, 2002 or The U. S. Army Chief of Staff's Professional Reading List, United States Army Center for Military History CMH Pub 10551.

Page 9 of 9 So please help us by uploading 1 new document or like us to download We are a nonprofit group that run this website to share documents. We need your help to maintenance this website. Indeed may be compensated by these employers, helping keep Indeed free for jobseekers. Indeed ranks Job Ads based on a combination of employer bids and relevance, such as your search terms and other activity on Indeed. For more information, see the Indeed Terms of Service Consolidated Consolidated jobs in Sandston, VA Sandston jobs Learn more about working at Coca Cola Bottling Co. Consolidated You can change your consent settings at any time by unsubscribing or as detailed in our terms.

The program of instruction challenges each cadet in the battalion in both indoor and outdoor settings; cadets participate in classroom instruction while also engaging in world class physical fitness training, land navigation, marksmanship, rappelling and other military activities. Cadets learn management and leadership skills not available in other University programs. Army ROTC experience contributes to a variety of job skills applicable to any profession, career or job, while

instilling in each cadet a sense of confidence, discipline, and personal responsibility. Moreover, each cadet gains the satisfaction of being part of a select group of great Americans dedicated to American values and service to the nation. As a fan of our page, you take personal responsibility for your comments, your username, and any information you submit. In that spirit, users are asked to adhere to the guidelines below. Violation of any of these guidelines may result in your comment being removed. Additionally, the appearance of external links, as posted by fans of this page or other Facebook users, does not constitute endorsement on behalf of the U.S. Army or the Department of Defense. Executive leadership opportunities are open for college students and graduates. ROTC Nurse Scholarship opportunities are open for college students and graduates. Not only can our scholarships cover up to four years of college tuition, it includes a stipend for books and monthly incidentals. The Rattler Battalion has now reached its 1702 2LT commissioned since 1932. Despite our current COVID crisis these fine young Lieutenants Made it Happen. CDT Kaysing, CDT Piatz, and CDT Sledge all have earned a 3 year Scholarship starting this Fall. They practiced throwing hand grenades, did a mock battle buddy live fire exercise, and qualified on the electronic pop up range. The cadets specifically enjoyed this one and got to show their skills in marksmanship.

It was a competition between the JROTC programs to see who could find the most points in the least amount of time. Awards were given out to the teams that placed, and booths were set up to promote the Rattler Battalions special teams. Our Cadets enjoyed interacting with, helping out, and explaining to the junior cadets what their future college life would be like in the Rattler Battalion. The lab was a rehearsal, ensuring all cadets know what they will be doing on the day of the event. The Orienteering meet will be this Saturday, 29 February 2020 and will be for the JROTC cadets in the San Antonio area. The goal is for the Cadets to do their best during 2 minutes of pushups, 2 minutes of situps, and end with a 2 mile run. Every time the Cadets take the test, a sense of friendly competition can be felt as they all want to see who can do the best and get the highest score. The Cadets tested their physical strength and resolve going up, down, over, and under each obstacle. They faced their fears and built confidence with each obstacle they overcame. The cadets set up in the forest and waited quietly for the patrol. They initiated the ambush with a claymore as the patrol passed and completed the mission with ease. This is a military tradition that represents a formal transfer of authority and responsibility for a unit from one commanding officer to another. We were able to recognize the outgoing Cadet Zane Martinez and Cadet Joshua Tinajero as the incoming Battalion Commander. This position is a huge responsibility and a great honor for any Cadet to receive. All cadets did a fantastic job pushing themselves through 18.6 miles to reach their time requirement. Congratulations to Cadets Aylin Hernandez, Seth Roen, Eric Sledge, Natalie Jimenez, Preston Robbins, Anna Lee, Malleigh Ebel, Kaitlyn Killebrew, Nicolas Miller, Michael Floore, Miguel Trevino, Hannah Wright, and our Cadre, Major Ferguson. You make the Rattler Battalion proud!

It may have been cold, but that didn't stop the cadets from having an intense game. An area defense was set up at St Marys Law Field to repel an incoming OPFOR attack. The defending cadets held firm against an aggressive assaulting force and learned a lot throughout the whole mission. A select few MS1s and MS2s set up a defense using barrels and natural cover while the rest of the battalion, led by MS3s, moved up and attacked the position. The cadets learned a lot from this lab and will put this knowledge to use in their future missions. The goal of the lab was to instruct and practice what to do with an enemy prisoner of war, or EPW, as well as how to perform aid on an injured person. The cadets performed exceptionally well during the practical exercise portion of the lab, exhibiting their grasp on the content taught. This event was designed to allow the Cadets to use what they learned from their military training labs to compete against one another. The Cadets were split into platoons and participated in a series of battles, ending with a one platoon identified as the Rattler Battalion paintball champions for the semester. With the semester soon coming to a close and the Fall FTX complete, cadets utilized this training to practice their land navigation skills and improve on areas of weakness when maneuvering through various terrains. Cadets began with a brief

refresher course on land navigation basics, giving junior cadets the opportunity to gain tips from their senior peers. Cadets then received a map of the training area, moved on to plotting three 8digit grid points, and began route planning. Cadets finally are encouraged to maneuver through the terrain individually, using only their map, a compass, critical thinking, and time management. The Rattler Battalion has learned over time, it is increased repetition of land navigation practice that produces the most success in their cadets.

It is one of the Rattler Battalions top priority to give its cadets the greatest opportunity for success in the basic soldiering skills. The Cadets gained valuable experience and familiarization with the M4 assault rifle, where they implemented the Army standard marksmanship techniques to zero and engage their targets from 25 to 300 meters. Cadets practiced firing from the standing, kneeling, prone supported, and prone unsupported firing positions. They were also given the opportunity to get real time positive feedback by applying what they learned by shooting at metal silhouette targets, which allowed them to hear and see them effectively engage a target from the 150 meters and also the 200 meter distance. This training will benefit the Cadets who will be attending Advance Camp in the summer of 2020, where they will be tested in their marksmanship abilities. This training took place under the careful coaching and supervision of Rattler Battalion cadre MSG Ramirez, SFC Eggert and MAJ Glosser Marys University campus, in the University Center. The ceremony was a great opportunity for Saint Mary's student veterans, their families, and all other guests to share a moment of appreciation and gratitude for our nations Veterans. The Saint Mary's University Wind Ensemble provided a salute to our Veterans, Soldiers, and Cadets in their amazing renditions of the National Anthem vocal by Eva Alpar, Senior Music Vocal major and the Armed Forces Medley. The audience were rewarded by hearing an incredibly inspirational speech by the ceremony's guest speaker CSM Thomas Oates, the Brookes Army Medical Center Command Sergeant Major. The Rattler Battalion would also like to extend our gratitude to President Mengler, REV Eden, and LTC Soto for their participation in the ceremony. The Cadets and Cadre held a tailgate, serving burgers and hotdogs to JROTC and Rattler Battalion Cadets, operating a recruitment table, and running the ROTC football toss in the UIW fan zone.

The Cadets had the opportunity to participate in the unfurling of the football field sized American flag during the National Anthem, and the Rattler Battalion pushup squad was in the endzone after every UIW score with a display of our Cadets physical fitness. The Rattler Battalion would like to thank Grunt Style for providing all ROTC and JROTC Cadets with military appreciation day tshirts, and Jimmy Johns who provided all Cadets with a deli box lunch! This competition consisted of several track and field events, swimming, first aid and NBC testing, pistol marksmanship qualification, and concluded with a 12 km road march with a 30lbs rucksack. In the end, Rattler Battalion had two Cadets qualify for the gold badge, three Cadets qualify for the silver badge, and one Cadet qualify for Bronze. Congratulations to Cadets Casey, Clark, Killbrew, Kujawa, Martinez and Miller for this individual achievement and for representing the Rattler Battalion at this prestigious event. Upon arrival, the cadets rucked three miles to their area of operations. They took a land navigation written test, followed by practical exercises consisting of two day iterations and one night iteration. The next morning, the cadets split into five squads and received their mission brief for simulated training exercises STX. Each squad conducted an attack, movement to contact, react to contact, ambush, and reconnaissance missions. These exercises were designed to test the cadets' tactical knowledge, mental agility, and leadership ability to assess how they handle stressful situations. On Sunday morning, the cadets received training on how to properly call for indirect fires as well as how to tactically cross open fields, roads, and trails before movement back to St. Mary's University. The Rattler Battalion showed up highly motivated, demonstrated a high level of proficiency in tough situations, and really showed what it means to be part of a team.

On October 8th, the Rattler Battalion had the pleasure of getting a visit from Command Sergeant

Major Bunn. Instead of the usual class curriculum, Cadets received a personal class on leadership and responsibility. Big shout out to the Command Sergeant Major for taking the time to provide our Cadets guidance, information and motivation on this morning! The team pushed themselves to physical and mental peaks as they competed in events such as the army combat fitness test, a tactical combat casualty care lane, rifle marksmanship, a grenades course, a onerope bridge, and an extremely rigorous commander's challenge. They had the challenge of training the firstyear cadets who composed half of the team, resulting in an outstanding performance. You can enter our program as a freshman, sophomore or once you have at least two years remaining at St. Marys as an undergrad or graduate student. We also have the Simultaneous Membership Program for those who are currently serving in the National Guard or Army Reserves as enlisted soldiers and wish to become officers. We at St. Marys Army ROTC challenge you to come and try our program. If you seek an opportunity to learn new skills, develop and exercise leadership abilities, and join a group of extraordinary young Americans who want more out of their college experience, then stop by or give us a call. St. Marys Army ROTC is a great place to start either for a few years or a full career in uniform, but whatever you do, Army ROTC will teach you leadership excellence for a lifetime! Marys University Army ROTC posts news and promotions. Your email address will not be used for any other purpose, and you can unsubscribe at any time. Marys University Army ROTC College of Arts, Humanities and Social Sciences at St. Marys University. University of the Incarnate Word. Trinity University. OLLU Our Lady of the Lake University U.S. Army Cadet Command ROTC College of Arts, Humanities and Social Sciences at St. OLLU Our Lady of the Lake University U.

<http://schlammatlas.de/en/node/18086>